

V1H751**V1H752**

Natural frequency : (1) 15 to 25 Hz
--



DESCRIPTION

The V1H751 and 752 range has a pressed steel casing and mounting plate and light alloy shaft. The resilient element is a stainless steel wire pad.

The steel parts are painted.

APPLICATIONS

The V1H 751 and 752 have a natural frequency between 15 and 25 Hz for static loads under compression.

The -11 and -12 versions are reinforced by radial cushions and can absorb considerable horizontal dynamic forces, which makes it possible to use them for mounting on board equipment in ships, rail, road transport, civil engineering plant (engines, pumps, generator sets, pipework) or fixed machines that have to be floor mounted.

(1) Natural frequencies with max/min loads, see : OPERATING CHARACTERISTICS.

DIMENSIONS

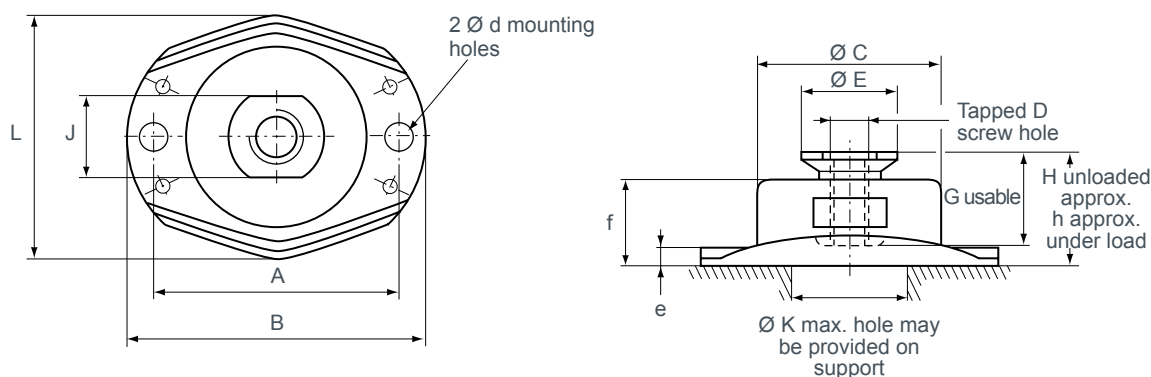

Reference	A (mm)	B (mm)	Ø C (mm)	D	Ø E (mm)	G (mm)	H (mm)	J (mm)	Ø K (mm)	L (mm)	Ø d (mm)	e (mm)	f (mm)	h (mm)
V1H751	92*	110	69	M12	32	47	54	27	40	90	11*	5,5	40,5	50
V1H752	126	152	96	M20	41	51	60	36	60	124	15	7	45	56

* Oblong holes with 2 mm aperture.

OPERATING CHARACTERISTICS

- Natural frequency :
 - axial } 15 to 25 Hz depending on load.
 - radial }
- Maximum permitted excitation at natural frequency of suspension : ± 0.4 mm.
- Amplification factor at resonance : < 4 .
- Structural strength corresponding to continuous acceleration under compression of 5 g for the 751 and 10 g for the 752 with maximum load.
- Operating temperature : $- 70^{\circ}\text{C}$ to $+ 300^{\circ}\text{C}$.
- Weight :
 - V1H751 : 0.75 kg;
 - V1H752 : 1.6 kg.

Reference	Static axial load (daN)	Maximum dynamic forces (daN)			Upper mounting screws		
		Compression	Tension	Radial	Take up length (mm)		Torque (m.N)
					mini	maxi	
V1H751-01	70 - 250	900	900	300	25	45	18
V1H751-11	70 - 250	900	900	800			40
V1H751-02	150 - 500	2 000	1 800	650			18
V1H751-12	150 - 500	2 000	1 800	1 600			40
V1H752-01	300 - 1 000	4 000	3 000	1 000	35	50	50
V1H752-11	300 - 1 000	4 000	3 000	3 000			140